

Product Selection &
Installation Guide



Ballistic Resistant Thermoset Composite Panels



Product Selection & Installation Guide



UL 752 & NIJ STANDARDS FOR BALLISTIC RESISTANT PROTECTIVE MATERIALS

UL Rating	NIJ Level	Ammunition	Velocity	No. Shots
Level 8	Level III	7.62mm rifle lead core full metal copper jacket, military ball	2750 ft/sec 838 m/sec	5



WALSHIELD+™ Ballistic Resistance ThermoSet Wall Panels

WIDTH / LENGTH	THICKNESS	COLOR
Sizes range from 36"x84" to 48"x120"	0.20 to 0.45 in 4.5 to 11 mm	Aesthetic films to order

CUSTOMIZED PANEL SIZES AND COLORS AVAILABLE.





INSTALLATION INSTRUCTIONS

WALSHIELD+[™] Ballistic Resistant Thermoset panels from FSJ Tactical can be field-fabricated using simple installation methods and common carpentry tools. Proper installation is necessary to achieve optimum ballistic resistance.

1. Lay out the project to utilize the largest panel sizes to minimize the number of seams.
2. Fabricate WALSHIELD+[™] to the desired size by cutting with a circular saw equipped with a diamond abrasive blade.
3. Secure the panels to steel or wood framing by mechanically fastening with heavy-duty wallboard or lag screws.
4. When constructing walls, rest the initial course of panels firmly on the floor to avoid any unsupported panel weight on the wall framing.
5. Reinforce all panel seams with a minimum 4 inch (10.16 cm) batten of additional ballistic panel material. Position these batten strips to cover the seam and attach to both panels using appropriate wallboard screws (see diagram).
6. Use overlapping butt joints when installing panels into corners.
7. Panels expand to absorb ballistic impact. When covering a sensitive substructure such as glass, shim the panels 3/8 inch (9.5 mm) to prevent impact shock damage.
8. Panels can be finished by covering with drywall, paneling, painting, or wall covering. Painting or wall covering will require the use of a suitable primer. When applicable, fire tests shall be performed on a finished wall system.

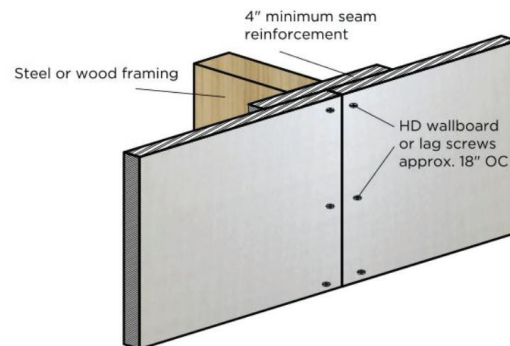



KEY CHARACTERISTICS

WALSHIELD+™ Ballistic Resistant ThermoSet Panels are thermally formed with layers of 0°/90° woven E-glass fiber reinforcements with a proprietary thermoset resin system. Additional protection against higher power ammunitions can be achieved by layering multiple panels; contact FSJ Tactical for information regarding your specific application.

USES AND APPLICATIONS

Ballistic resistant composite panels from FSJ Tactical are suitable for indoor and outdoor use in commercial, governmental, industrial, and residential applications:

- Military Structures
- Check Cashing
- Courtrooms
- Bonded Warehousing
- Safe Rooms
- Infrastructure Facilities & Equipment
- Pawn Shops
- Police Stations
- Security Buildings
- Storm Shelters
- Banking
- Loan & Bail/Bond Offices
- Detention Facilities
- Equipment Storage
- Judges' Chambers

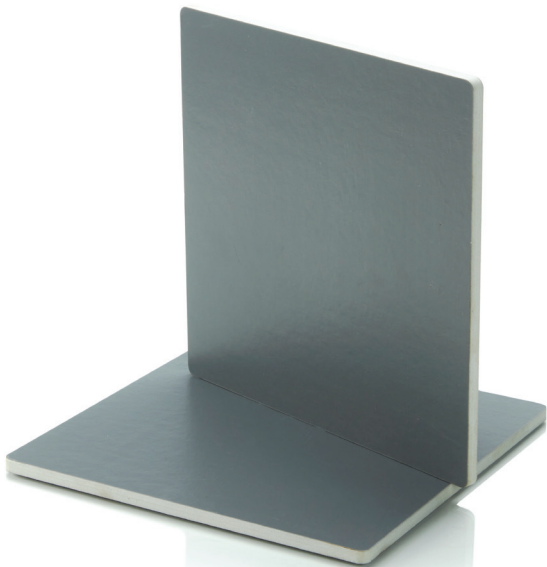

(602) 762-5650
fernando@fsjtactical.com